

FD 120-17 CI

Double Convolution Air Spring

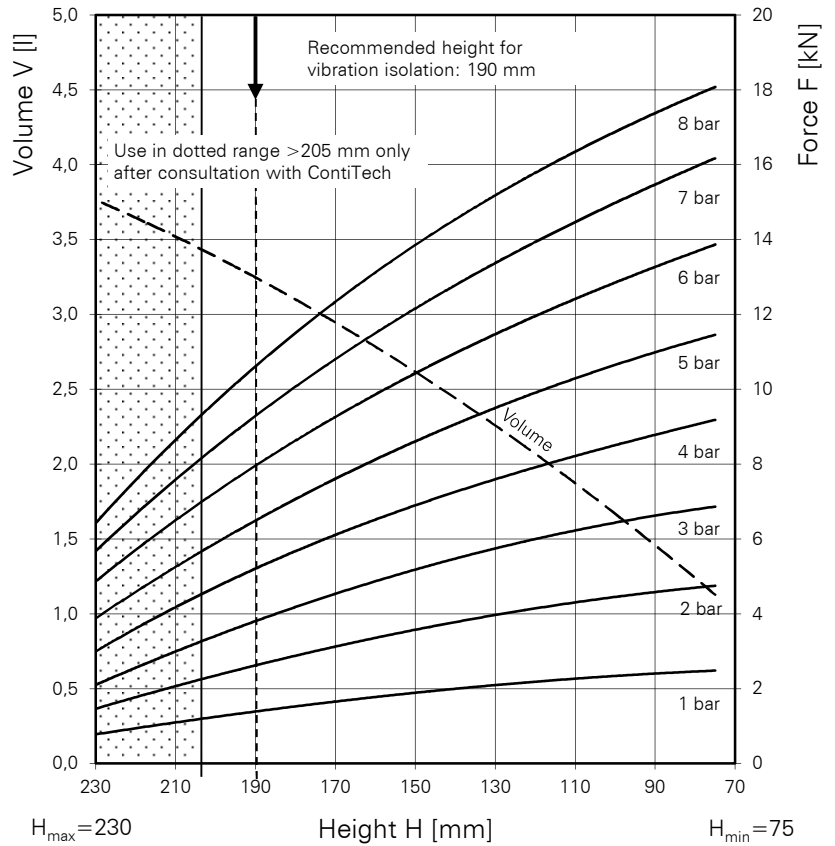
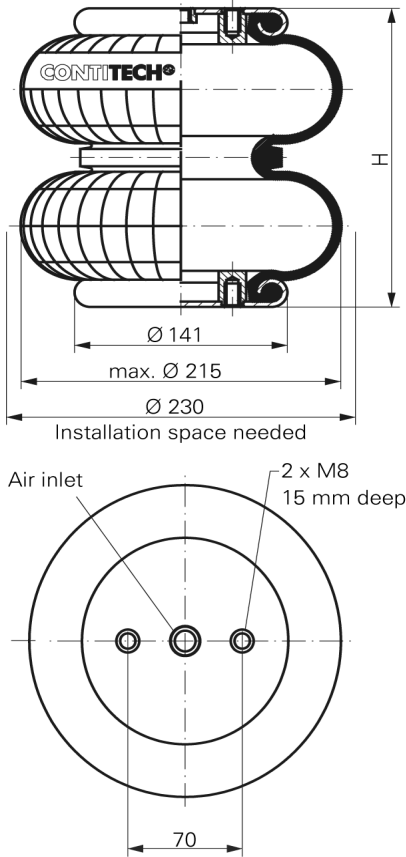

Purchase order data

Type	Order No.
Rubber bellows only	60221
With clamped plates G 3/4 air inlet	2682 030 000
With clamped plates G 1/4 air inlet	61361

Additional types on request

Technical data

Min. pressure	0 bar
Return force to min. height	≤ 200 N
Overall weight with clamped plates	2.3 kg

Vibration isolation - dynamic characteristic values

Design height H: recommended 190mm, minimum 175mm

Pressure p [bar]	3	4	5	6	7	8	Vol [l]
Force (Load) [kN]	3.8	5.2	6.5	8.0	9.3	10.6	3.2
Spring rate [N/cm]	600	830	1060	1290	1520	1750	
Natural frequency [Hz]	2.1	2.0	2.0	2.0	2.0	2.0	

Pneumatic application - static characteristic values

Force F [kN]

Pressure p [bar]	3	4	5	6	7	8	Vol.[l]	
Height H [mm]	200	3.4	4.8	5.9	7.3	8.5	9.7	3.4
	180	4.2	5.7	7.1	8.6	10.1	11.5	3.1
	160	4.9	6.5	8.1	9.9	11.5	13.1	2.8
	140	5.5	7.2	9.1	11.0	12.7	14.5	2.4
	120	6.0	7.9	9.9	12.0	14.0	15.8	2.1
	100	6.4	8.5	10.7	12.9	15.1	17.0	1.6
	80	6.8	9.1	11.3	13.7	16.0	17.9	1.2

Measuring procedure: Room temperature / Force- height- data quasistatic / Dynamic data at 1 Hz



Service instructions
M8 = 25 Nm
G 1/4 = 25 Nm
G 3/4 = 50 Nm