

# FD 200-25 CI

# Double Convolution Air Spring

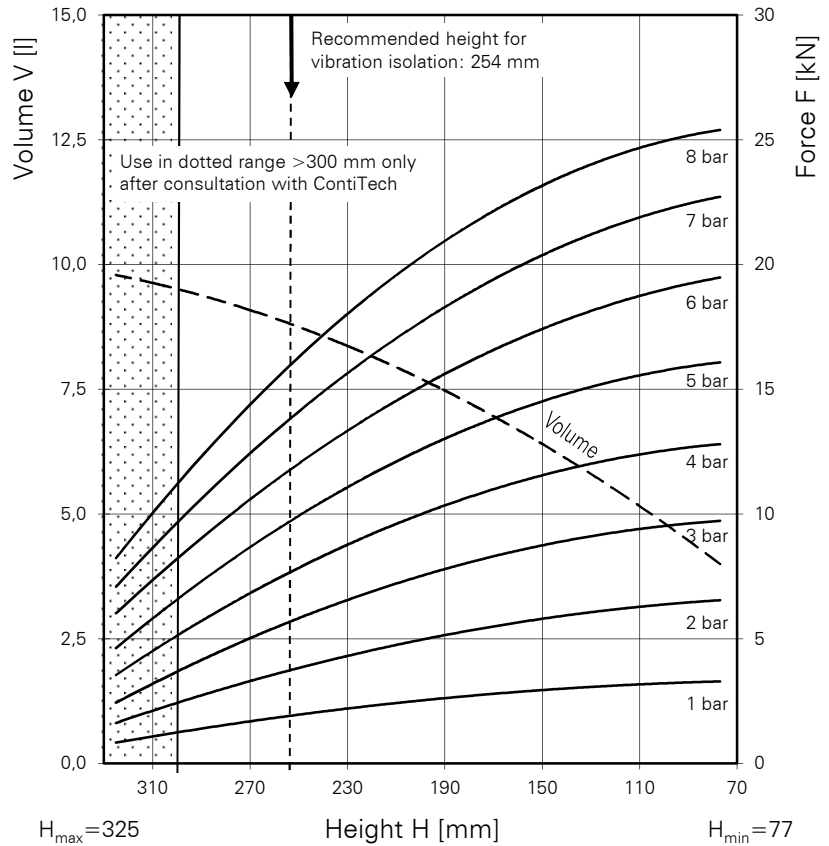
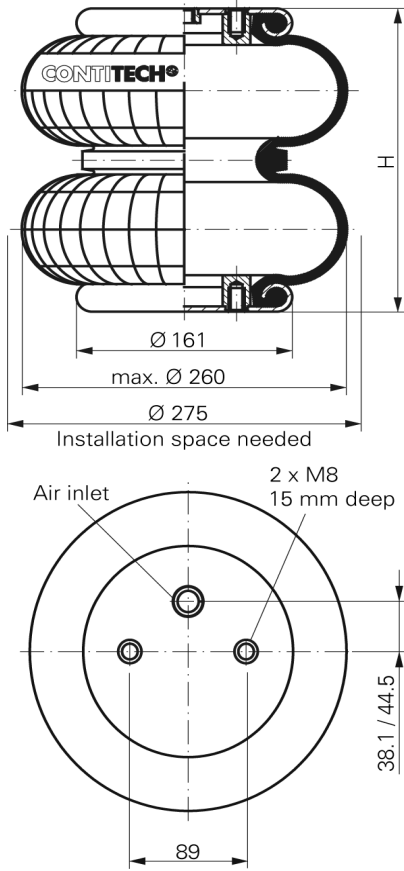

### Purchase order data

Type	Order No.
Rubber bellows only	60515
With clamped plates G 3/4 air inlet 38.1 mm excentric	60382
With clamped plates G 1/4 air inlet 44.5 mm excentric	60555
With stainless steel clamped plates G 3/4 air inlet 38.1 mm excentric	67781

Additional types on request



Service instructions

M 8 = 25 Nm

G 1/4 = 25 Nm

G 3/4 = 50 Nm

### Technical data

Min. pressure	0 bar
Return force to min. height	≤ 250 N
Overall weight with clamped plates	3.5 kg

#### Vibration isolation - dynamic characteristic values

Design height H: recommended 254mm, minimum 230mm

Pressure p [bar]	3	4	5	6	7	8	Vol. V[l]
Force (Load) [kN]	6.0	8.1	10.2	12.3	14.4	16.5	
Spring rate [N/cm]	730	930	1200	1390	1660	1840	
Natural frequency [Hz]	1.8	1.8	1.7	1.7	1.7	1.7	

#### Pneumatic application - static characteristic values

Force F [kN]

Pressure p [bar]	3	4	5	6	7	8	Vol.[l]
Height H [mm]	290	4.1	5.6	7.3	9.0	10.5	9.4
	260	5.6	7.3	9.4	11.3	13.4	8.9
	230	6.6	8.8	11.1	13.4	15.8	8.4
	200	7.5	9.9	12.5	15.0	17.6	7.7
	170	8.3	11.0	13.8	16.6	19.4	7.0
	140	8.9	11.8	14.8	17.7	20.7	6.1
	110	9.3	12.3	15.6	18.7	21.9	5.1

Measuring procedure: Room temperature / Force- height- data quasistatic / Dynamic data at 1 Hz